

THE ALPHA LIQUID SCINTILLATION

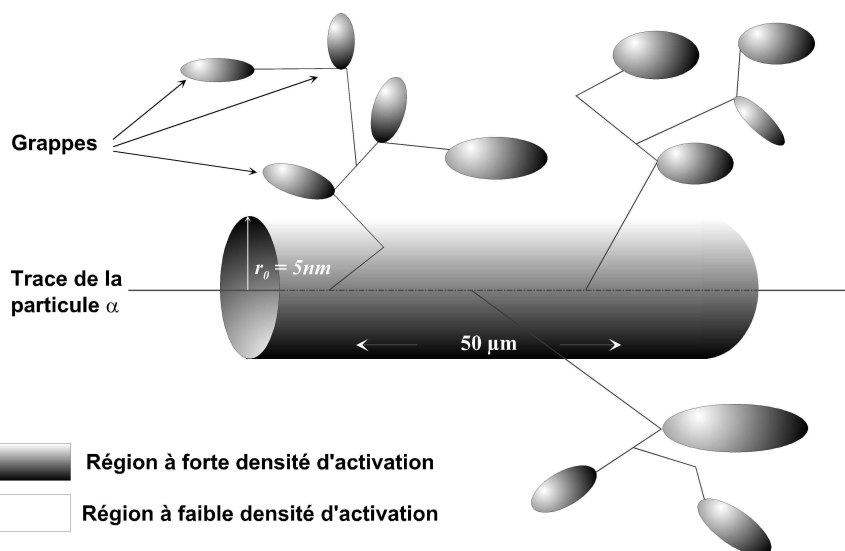

Production of excited states

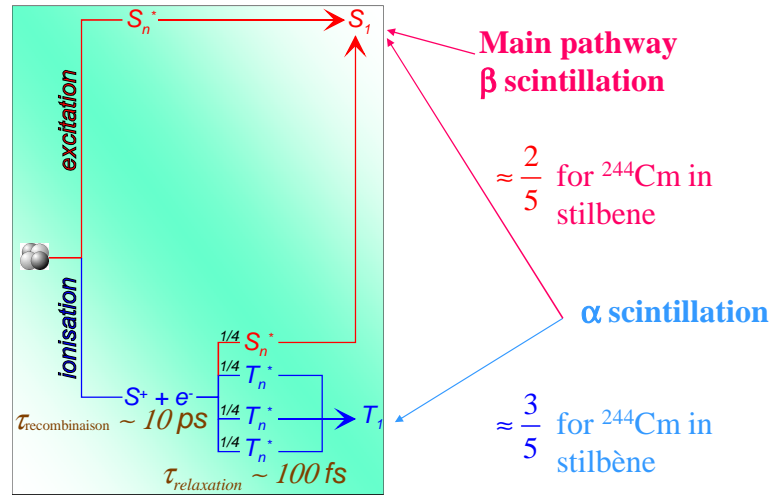

The alpha liquid scintillation

3

Mechanism of interaction - singlet



The alpha liquid scintillation

4

Mechanism of interaction - triplet

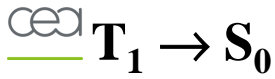

**Internal
deexcitation**

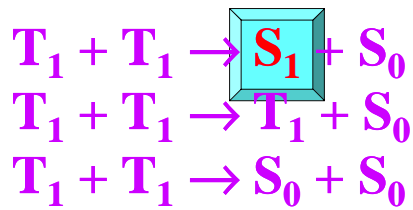

Annihilations

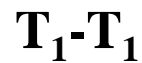

FÖRSTER THEORY



Reactions of deexcitation
(energy loss)

$$R_0^6 = \frac{9000 \ln 10 \kappa^2 \phi_D}{128 \pi^6 n^4 N} \int_0^\infty f_D(\nu) \epsilon_A(\nu) \frac{d\nu}{\nu^4}$$

$$k_{SF} = \frac{1}{\tau_D} \left(\frac{R_0}{R} \right)^6$$

Equation of Gösele (1975)

Probability of one state to be still excited at a given time t



Fluorescence

Coulombian interaction

$$\rho(t) = \exp\left(-\frac{t}{\tau_D} - 4\pi D r_F n_A t - g \frac{4}{3} \pi^{3/2} n_A R_0^3 \sqrt{\frac{t}{\tau_D}}\right)$$

With:

$$r_F \approx 0.676 R_0^4 g^2 \frac{R_0^2}{\tau_D D}$$

The alpha liquid scintillation

7

Example of kinetics of transfer

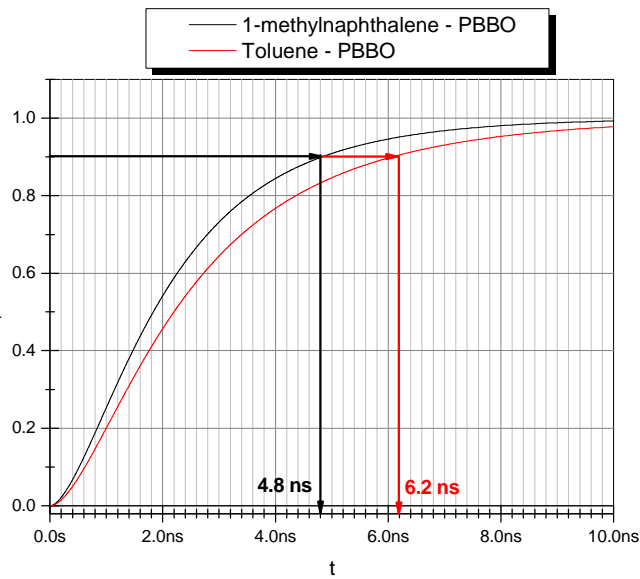

The alpha liquid scintillation

8

EXTRACTIVE-SCINTILLATING MIXTURE

- **Extractant :**
specific for a α emitter.



• Scintillating mixture (fluor) :

Solvent : toluene (7.5 M)

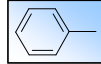

Amplifier of α/β discrimination :

naphthalene (1,5 M)

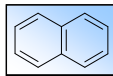

UV dye : PBBO (10^{-2} M)

2(4biphenyl) 6 - phenylbenzoxazole

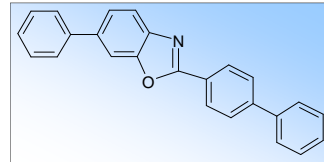

The alpha liquid scintillation

9

Formation Toluene Naphthalene PBBO

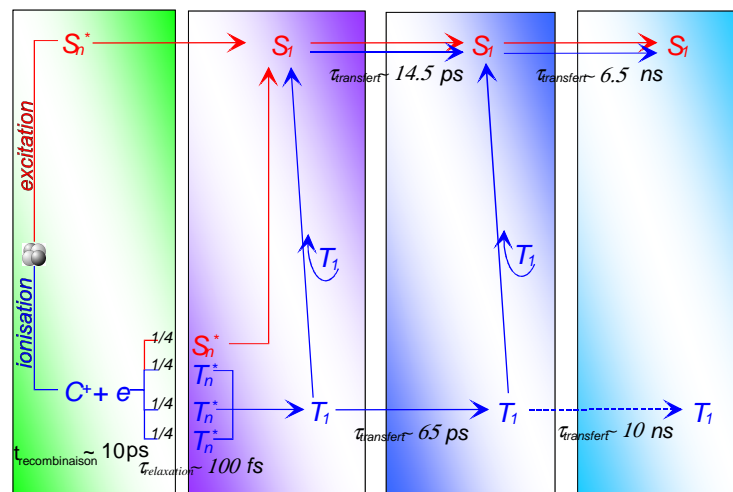

The alpha liquid scintillation

10

Available data – kinetic constants

	Mechanism	k_i Toluene	k_i Naphthalene	k_i PBBO
ceei Fluorescence	$S_1 \rightarrow S_0 + h\nu$	$4.1 \cdot 10^6 \text{ s}^{-1}$	$2.0 \cdot 10^6 \text{ s}^{-1}$	$8.3 \cdot 10^8 \text{ s}^{-1}$
	inter-crossing syst. $S_1 \rightarrow T_1$	$1.6 \cdot 10^7 \text{ s}^{-1}$	$7.8 \cdot 10^6 \text{ s}^{-1}$	
Internal deexcitat.	$S_1 \rightarrow S_0$	$9.8 \cdot 10^6 \text{ s}^{-1}$	$6.3 \cdot 10^5 \text{ s}^{-1}$	
	Quenching $S_1 + Q \rightarrow S_0 + Q$ ($Q = O_2$)	$2.8 \cdot 10^{10} \text{ M}^{-1} \cdot \text{s}^{-1}$ (in cyclohexane)	$2.7 \cdot 10^{10} \text{ M}^{-1} \cdot \text{s}^{-1}$ (in cyclohexane)	
Phosphorescence	$T_1 \rightarrow S_0 + h\nu$	$4.7 \cdot 10^{-2} \text{ s}^{-1}$	$1.4 \cdot 10^{-2} \text{ s}^{-1}$	
Internal deexcitat.	$T_1 \rightarrow S_0$	$8.2 \cdot 10^{-2} \text{ s}^{-1}$	0.42 s^{-1}	
Quenching	$T_1 + Q \rightarrow S_0 + Q$ ($Q = O_2$)	$1.3 \cdot 10^9 \text{ M}^{-1} \cdot \text{s}^{-1}$ (in benzène)	$1.5 \cdot 10^9 \text{ M}^{-1} \cdot \text{s}^{-1}$ (in benzène)	
			$2.4 \cdot 10^9 \text{ M}^{-1} \cdot \text{s}^{-1}$ (in toluène)	
T_1 - T_1 annihilation	$1-T_1 + T_1 \rightarrow S_1 + S_0$?	?	$R = 0.56$ <i>Driven by diffusion</i>
	$2-T_1 + T_1 \rightarrow T_1 + S_0$?	?	
	$3-T_1 + T_1 \rightarrow S_0 + S_0$?	?	
	$T_1' + S_0'' \rightarrow S_0' + T_1''$	$1.5 \cdot 10^{10} \text{ s}^{-1}$	$1 \cdot 10^8 \text{ s}^{-1}$	
T_1 energy transfer				
	S_1 energy transfer $S_1 + F_0 \rightarrow F_1 + S_0$	$6.9 \cdot 10^{10} \text{ s}^{-1}$	$1.5 \cdot 10^8 \text{ s}^{-1}$	

The alpha liquid scintillation

11

Delayed fluorescence

ceei

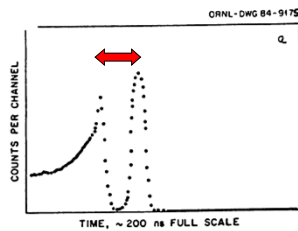

Fluorescence retardée due au toluène par interaction triplet-triplet sur le toluène

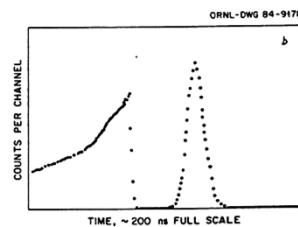

Fluorescence retardée due au naphthalène par interaction triplet-triplet sur le naphthalène

The Effect on Pulse-Shape (Time) Resolution due to Naphthalene Concentration in the Scintillator: a. No naphthalene in the scintillator, b. 200g/L

The alpha liquid scintillation

12

Energy levels S_1 and T_1

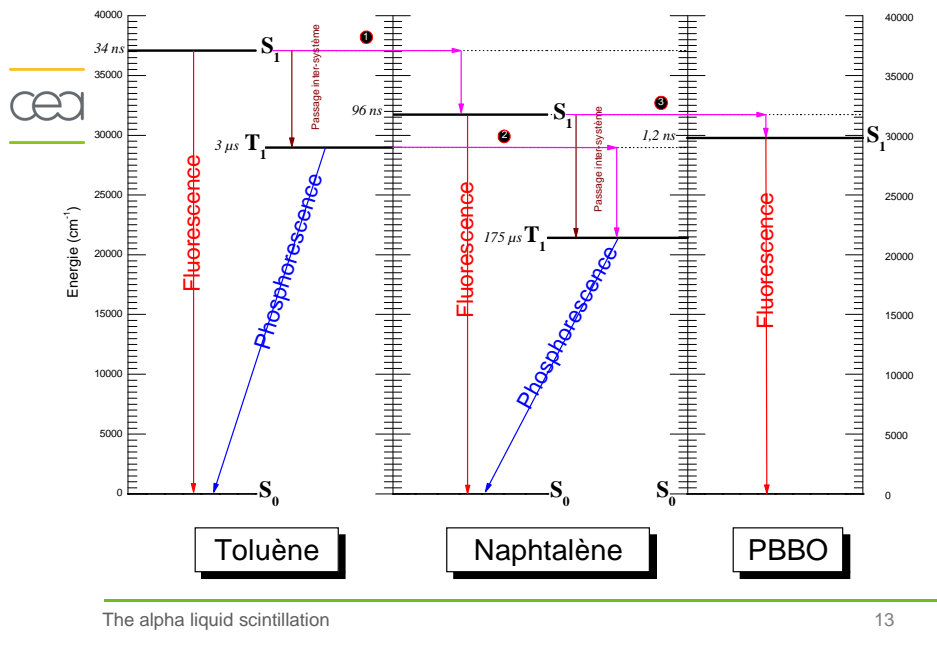

Spectra of components present in Alphaex

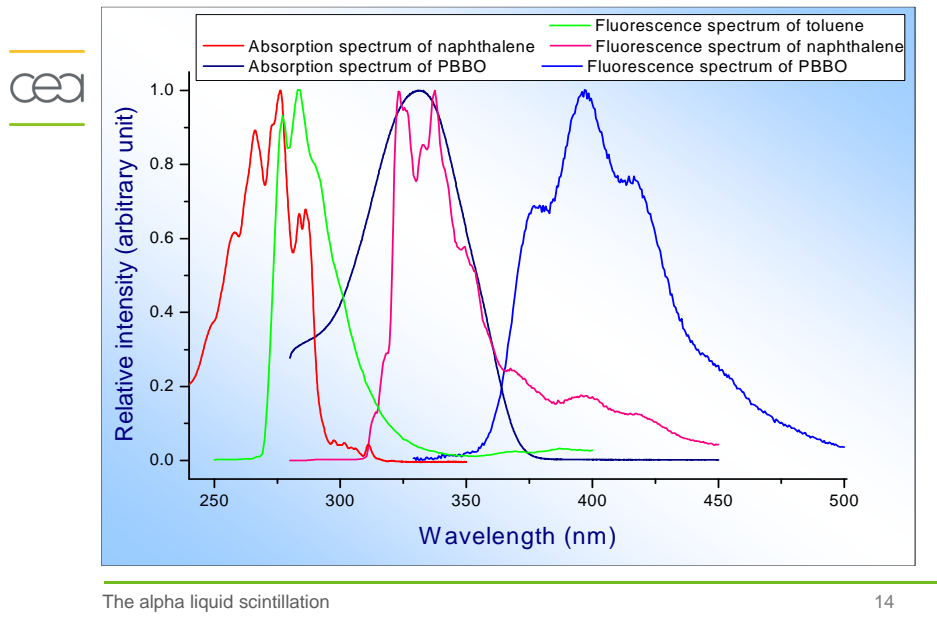

Principle

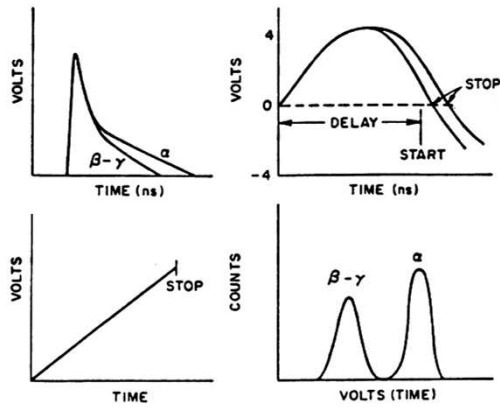
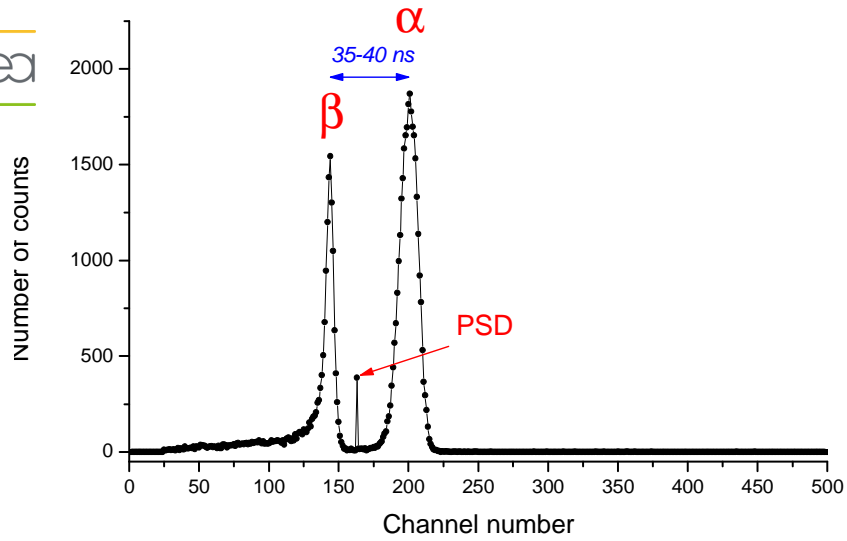

Fig. 21. Pulse-Shape Discrimination. This is possible because the detectable portion of alpha-produced light pulses (upper left) last about 30 nanoseconds longer than beta- or gamma-produced pulses. Since the integrated pulses (upper right) are about a microsecond long, the beginning of timing is delayed for about 300 nanoseconds. A voltage ramp (lower left) is then started and rises linearly with time until the pulse crosses zero. The spectrum of these voltage pulses (lower right) represents alpha (right) and beta-gamma pulses (left).

The alpha liquid scintillation

15



The alpha liquid scintillation

16

Discrimination and α energy

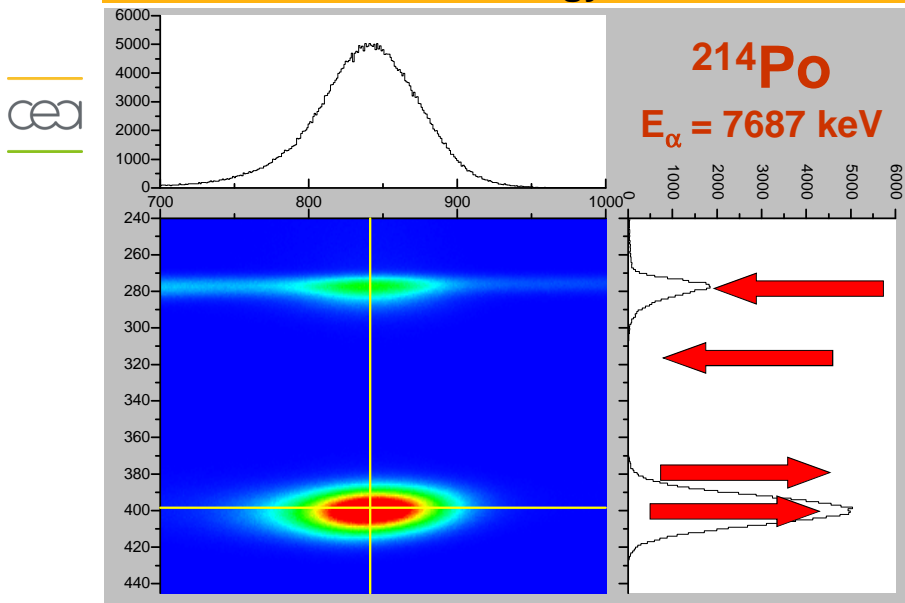

The alpha liquid scintillation

17

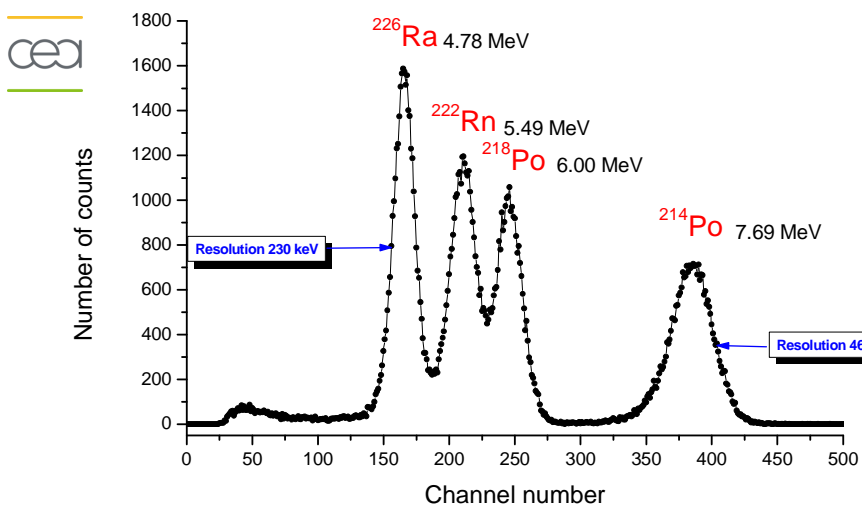

The alpha liquid scintillation

18

Bi-parametric mode

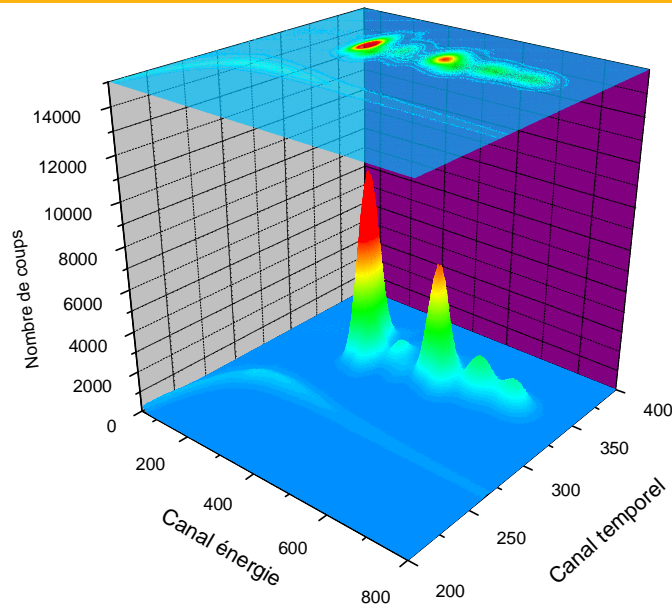

The alpha liquid scintillation

19

Treatment of spectra

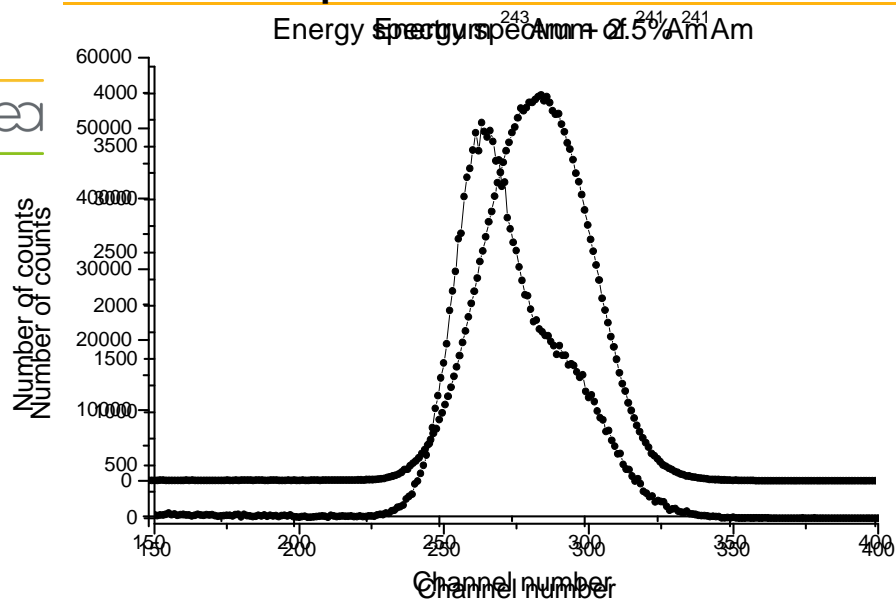

The alpha liquid scintillation

20

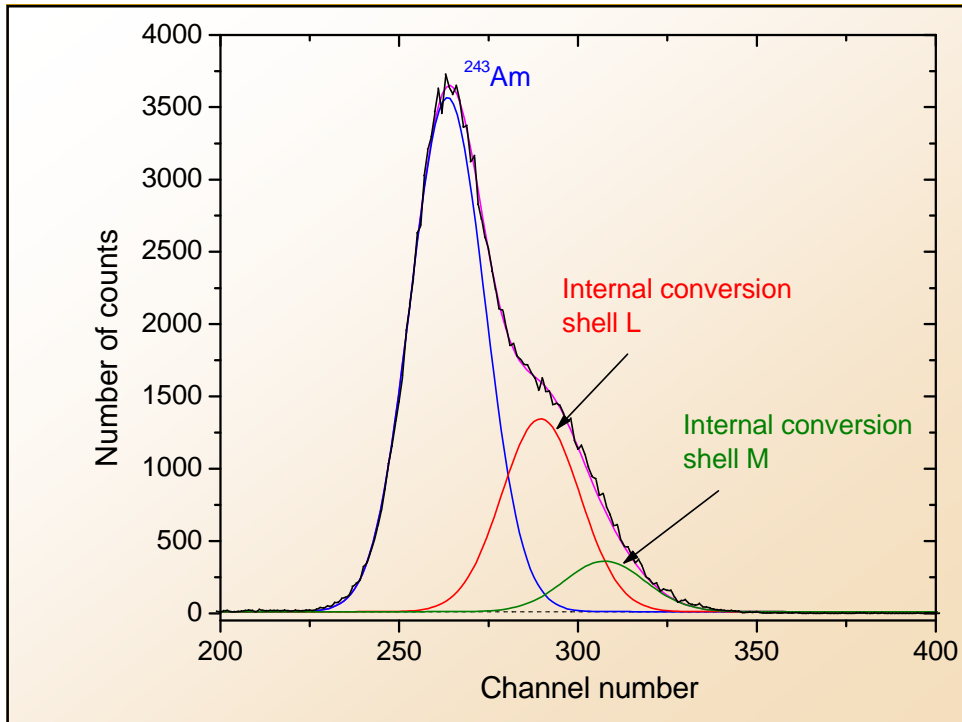
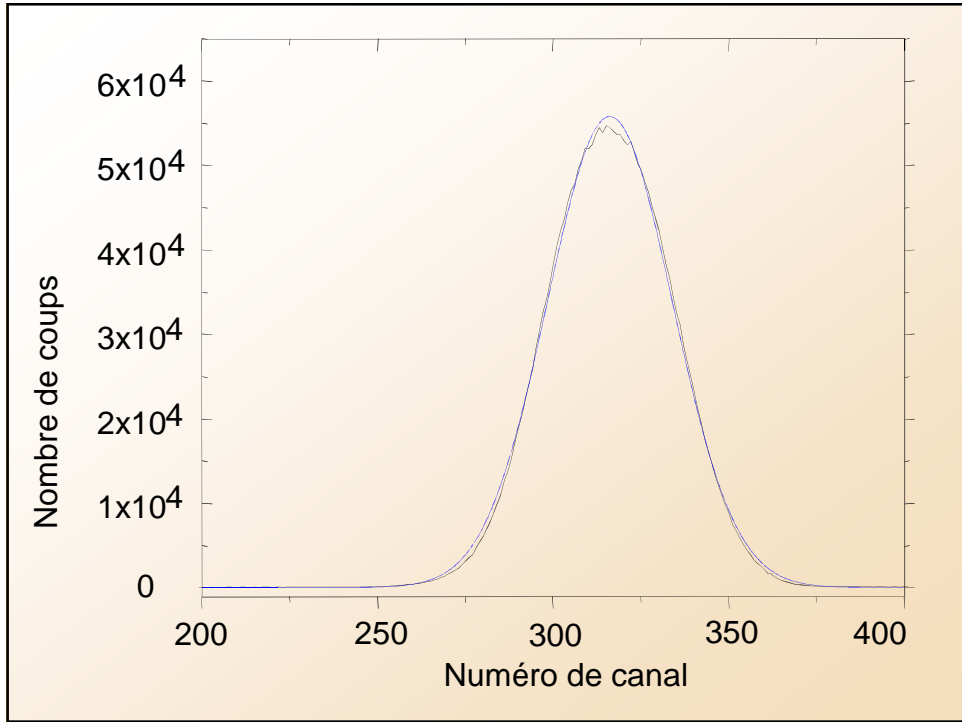

Data base



Radionuclide	E_{α} (keV) ^a	Relative intensity normalised to the main α ray I_{α}^{rel} (%)	Absolute intensity ^b (%)
²³⁸ U #	4196	100	79.16
IC L-shell	4388	19.16	15.17
IC M-shell + ...	4512	7.16	5.67
²³⁴ U	4775	100	71.70
IC L-shell	4988	28.73	20.60
IC M-shell + ...	5112	10.74	7.70
²³² U	5320	100	68.65
IC L-shell	5566	33.24	22.82
IC M-shell + ...	5690	12.43	8.53
²³² Th	4010	100	78.56
IC L-shell	4307	19.90	15.63
IC M-shell + ...	4386	7.40	5.81
²³⁰ Th	4688	100	76.97
IC L-shell	5011	21.40	16.81
IC M-shell + ...	5128	7.92	6.22
²²⁸ Th	5423	100	74.00
IC L-shell	5865	25.65	18.98
IC M-shell + ...	5982	9.49	7.02
²³⁹ Pu	5157	100	88.54
IC L-shell	5349	9.40	8.32
IC M-shell + ...	5480	3.55	3.14
²⁴⁰ Pu	5168	100	72.94
IC L-shell	5316	27.23	19.86
IC M-shell + ...	5448	9.87	7.20
²³⁶ Pu	5768	100	68.37
IC L-shell	5933	34.24	23.41
IC M-shell + ...	6064	12.02	8.22
²⁴¹ Am	5233	17.63	12.10
IC L-shell	5275	100	68.65
IC M-shell + ...	5698	21.03	14.44
	6060	7.01	4.81

The alpha liquid scintillation

23

Examples : other actinides spectra

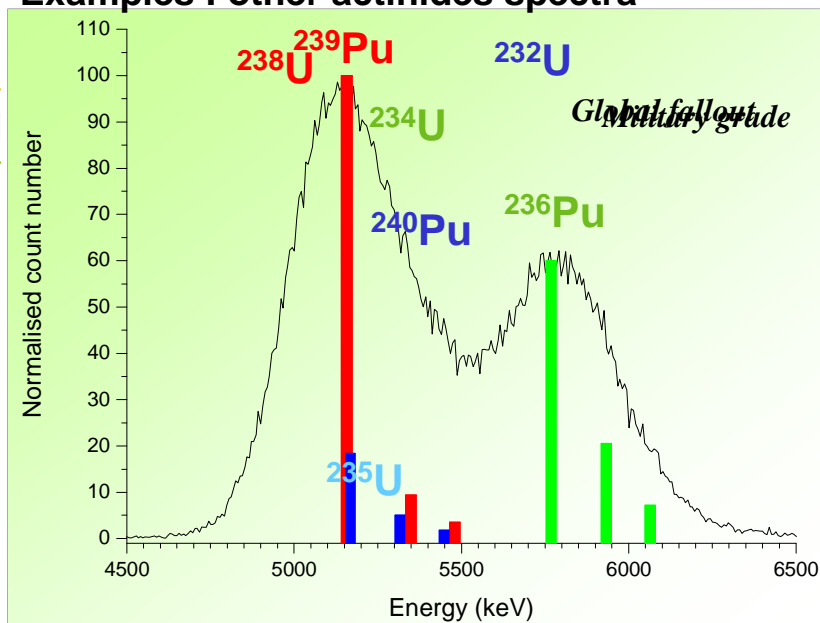

The alpha liquid scintillation

24

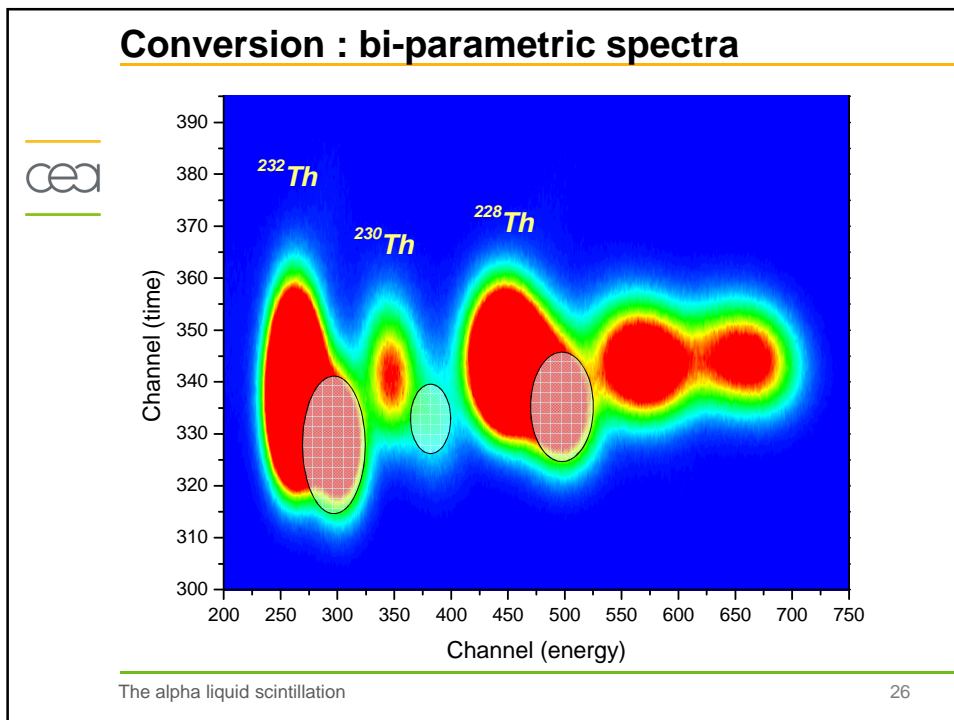
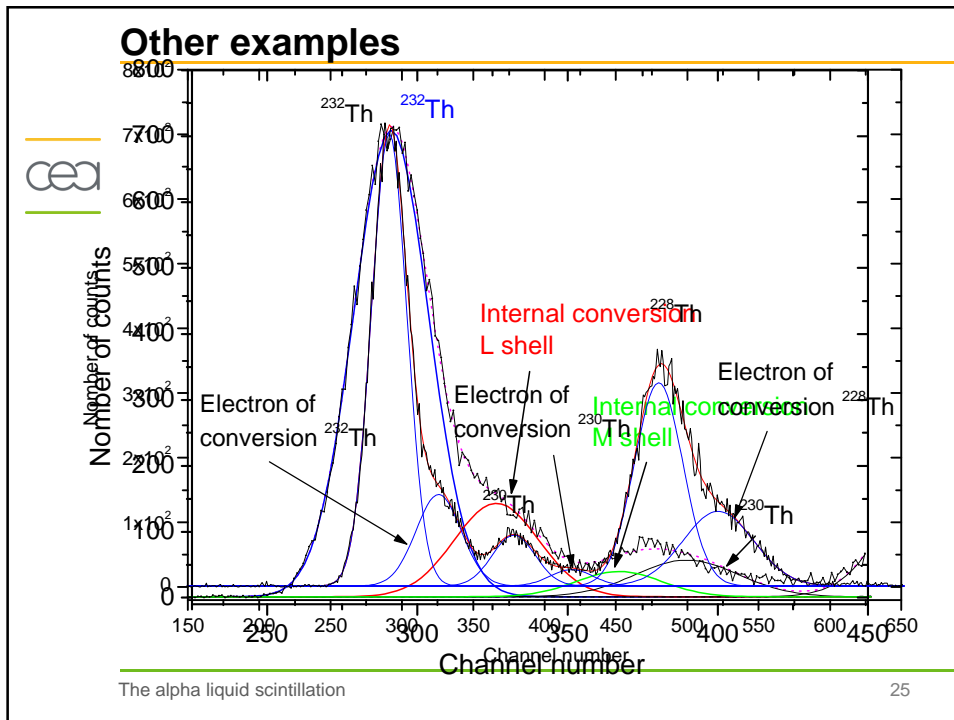

APPARATUS



The alpha liquid scintillation

27

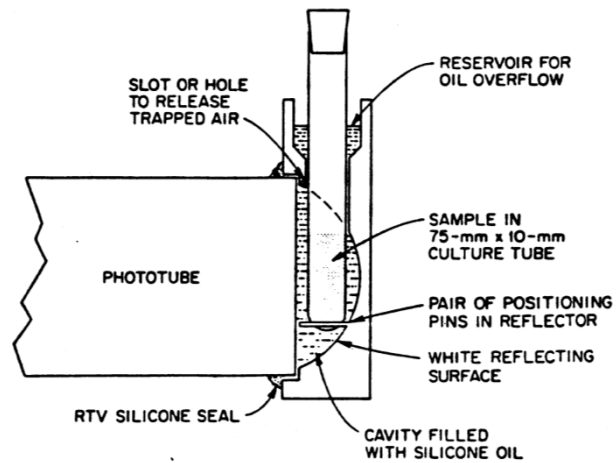

Fig. 11. Cross Section of a Single-Phototube Detector/Reflector/Sample Holder found Suitable for Alpha Liquid Scintillation Spectrometry

The alpha liquid scintillation

28

Quantulus



The alpha liquid scintillation

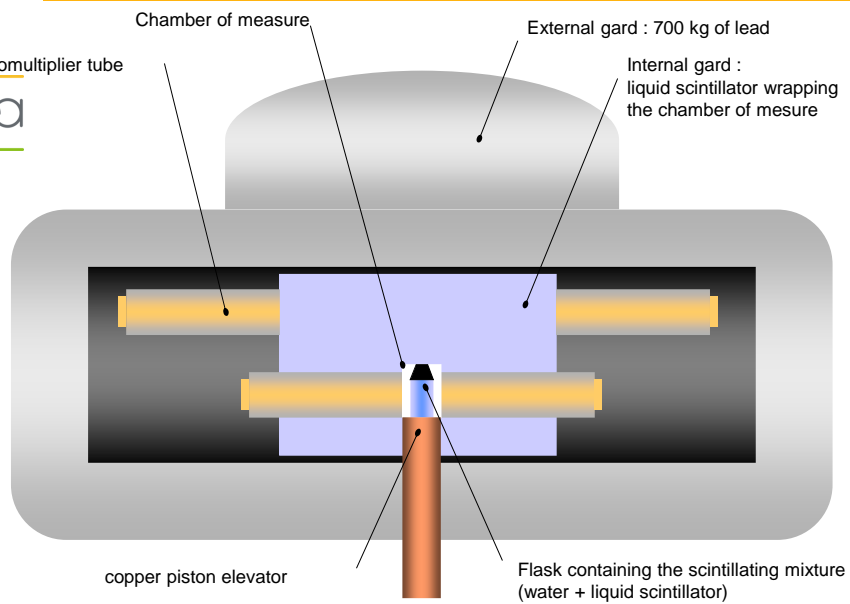

The alpha liquid scintillation

Quenching of extractants

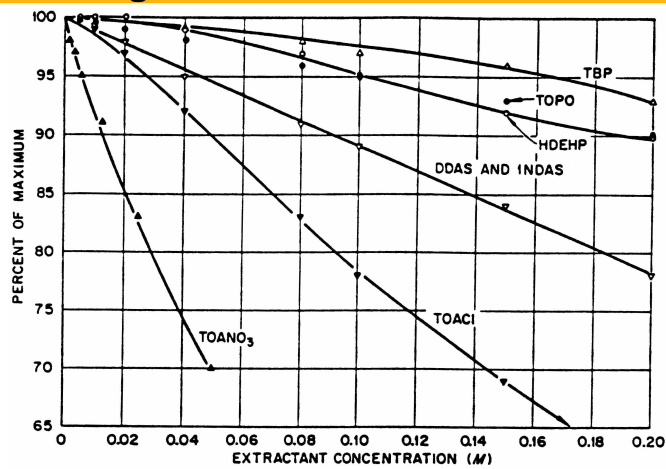

The Quenching Effect of Various Extractants: TBP = tributylphosphate, TOPO = trioctylphosphine oxide, DDAS = didecylamine sulfate, 1NDS = 1-nonyldecylamine sulfate, TOACl = trioctylamine chloride, and TOANO₃ = trioctylamine nitrate.

The alpha liquid scintillation

31

Applications



Extraction of actinides :

1. Extractive scintillating mixture - URAEX : **tri-n-octylamine – sulfate medium**
2. Extractive scintillating mixture THOREX : **1-nonyl-decylamine – sulfate medium**
3. Extractive scintillating mixture ALPHAEX : **HDEHP – free medium**

The alpha liquid scintillation

32

Remark: other mixtures :



1. Extractive scintillating mixture
RADAEX (Ra) : **Cy₂-21C7** + **acid heptanoic**
2. Extractive scintillating mixture POLEX
(Po) : **TOPO**
3. Extractive scintillating mixture
STRONEX (Sr) : **crown ether**
4. Extractive scintillating mixture
RADONS (Rn) : **toluene ϕ -CH₃**

Quenching (color & chemical)

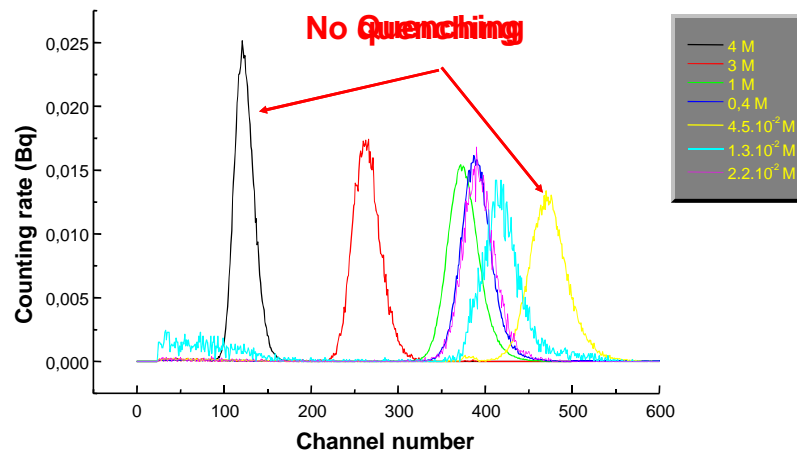
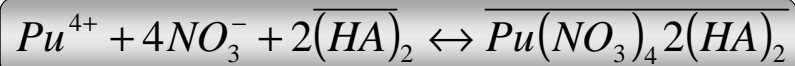

LIQUID-LIQUID EXTRACTION

$$P = \frac{D \bar{V} / V}{1 + D \bar{V} / V} \times 100$$

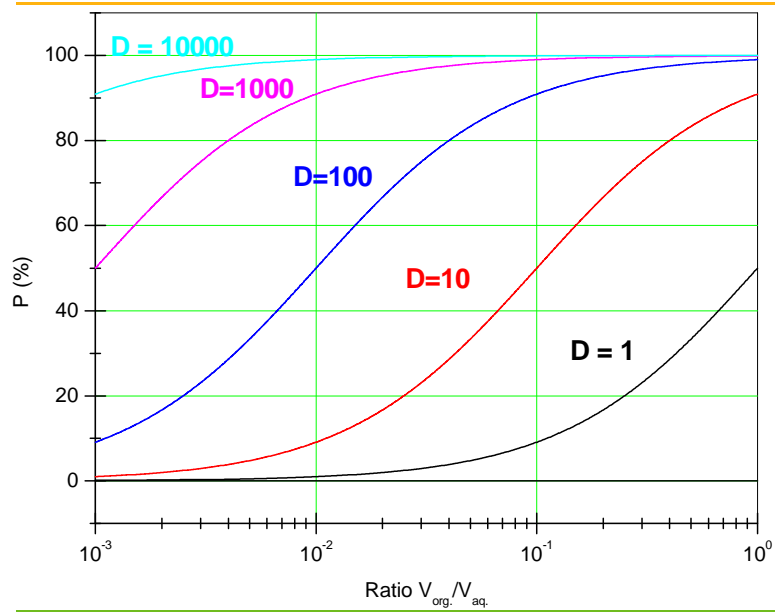

Examples

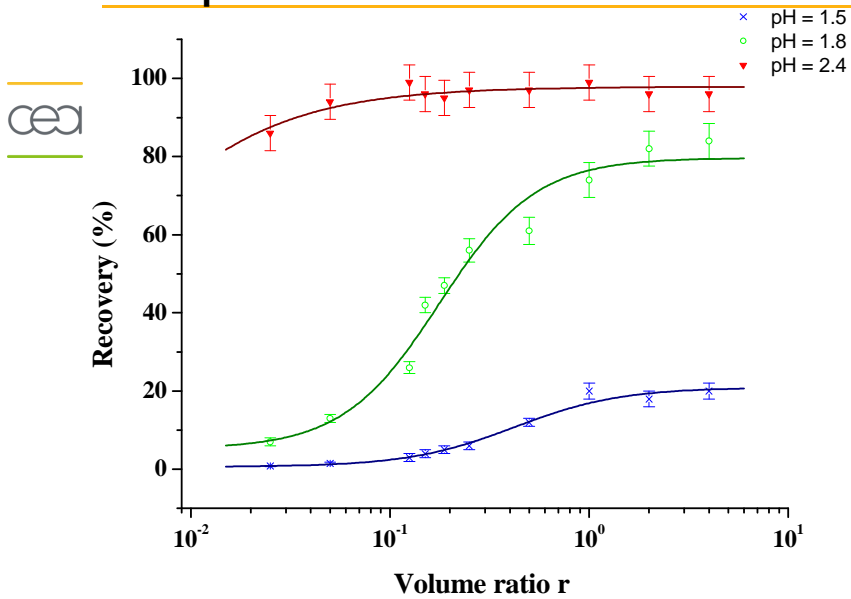

The alpha liquid scintillation

37

Neutral extractant : TOPO

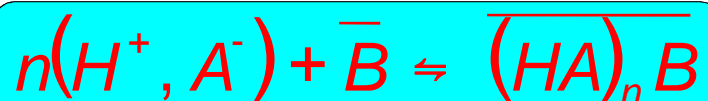
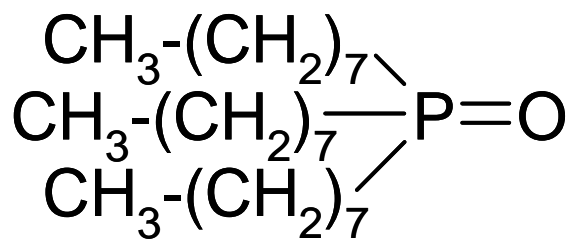

The alpha liquid scintillation

38

Extraction Curves - TOPO - HCl

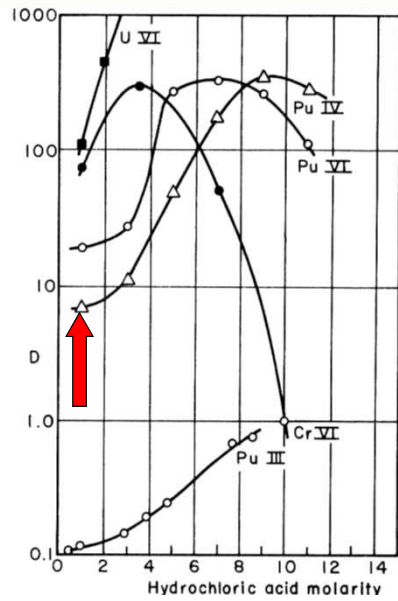

The alpha liquid scintillation

39

Effet relargant



POLEX
 $\text{HNO}_3\text{-NH}_4\text{NO}_3$

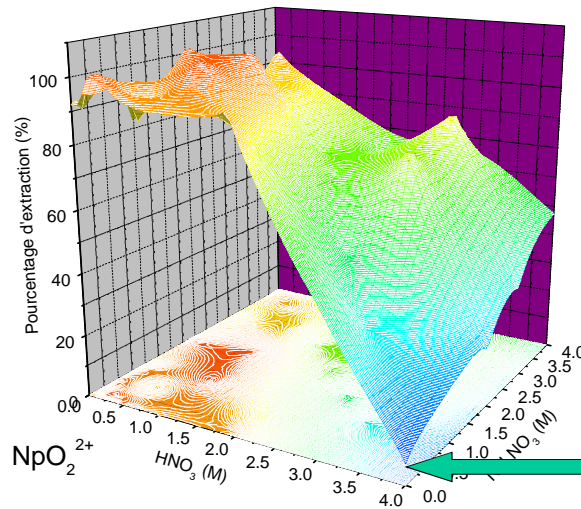

The alpha liquid scintillation

40

Extraction of actinides by TNOA

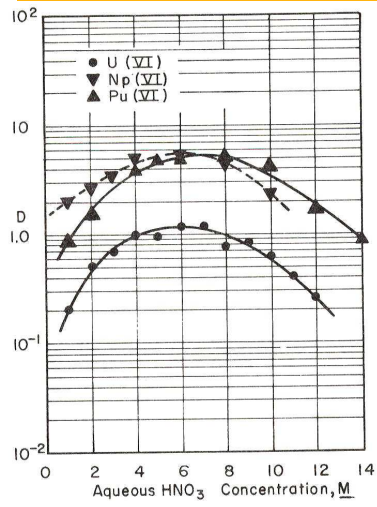

The extraction of the hexavalent actinide nitrates by 10 v/o TOA in xylene. 219

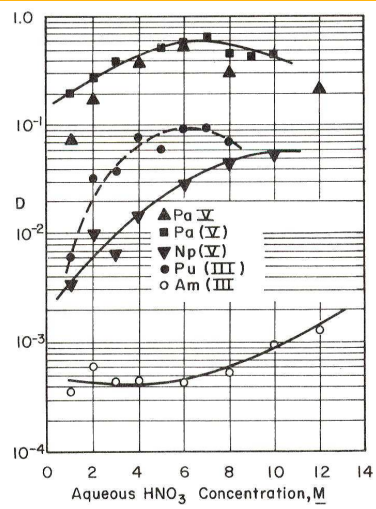

The extraction of pentavalent and trivalent actinide nitrates by 10 v/o TOA in xylene. 219

The alpha liquid scintillation

43

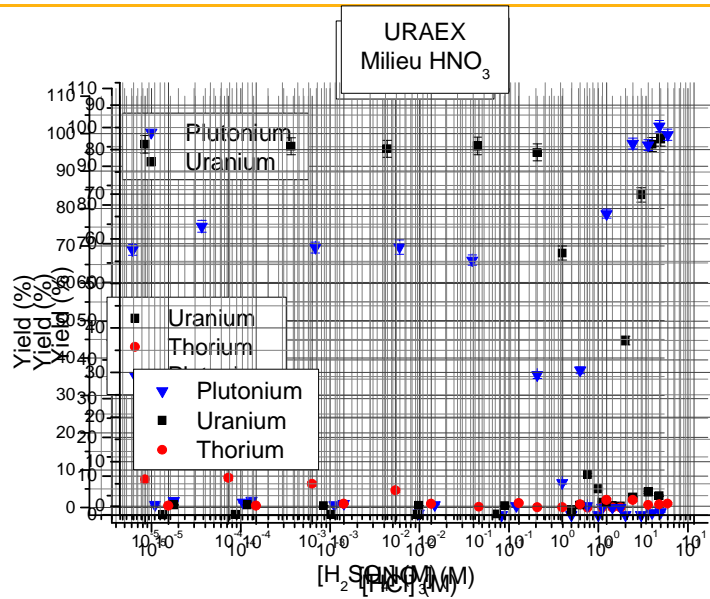

The alpha liquid scintillation

44

Case of acidic extractants

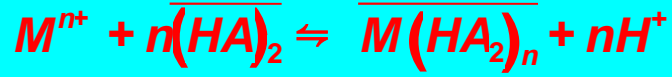
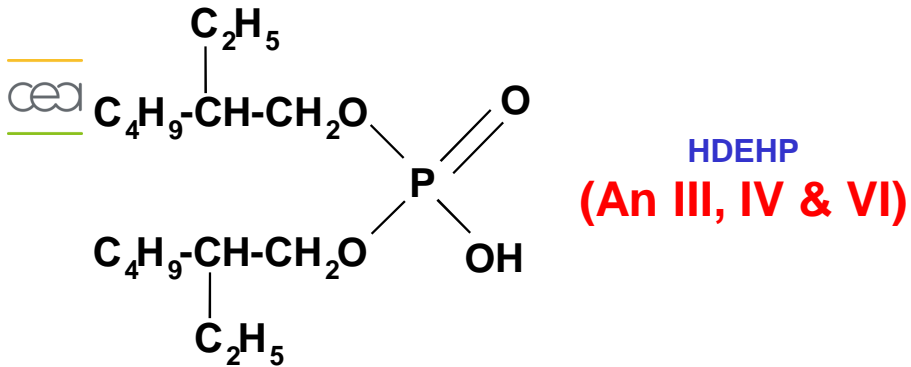

Extraction of actinides by HDEHP

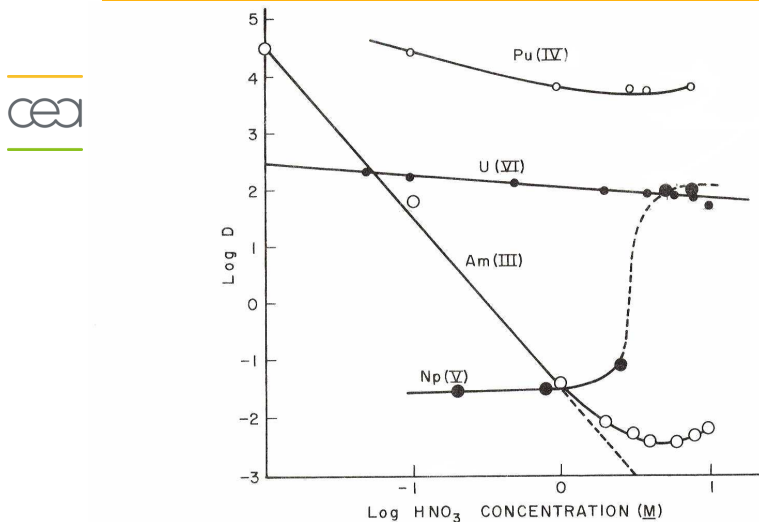

Extraction of various actinides into 0.5 M HDEHP (isooctane diluent) from HNO_3 solutions.²³⁸

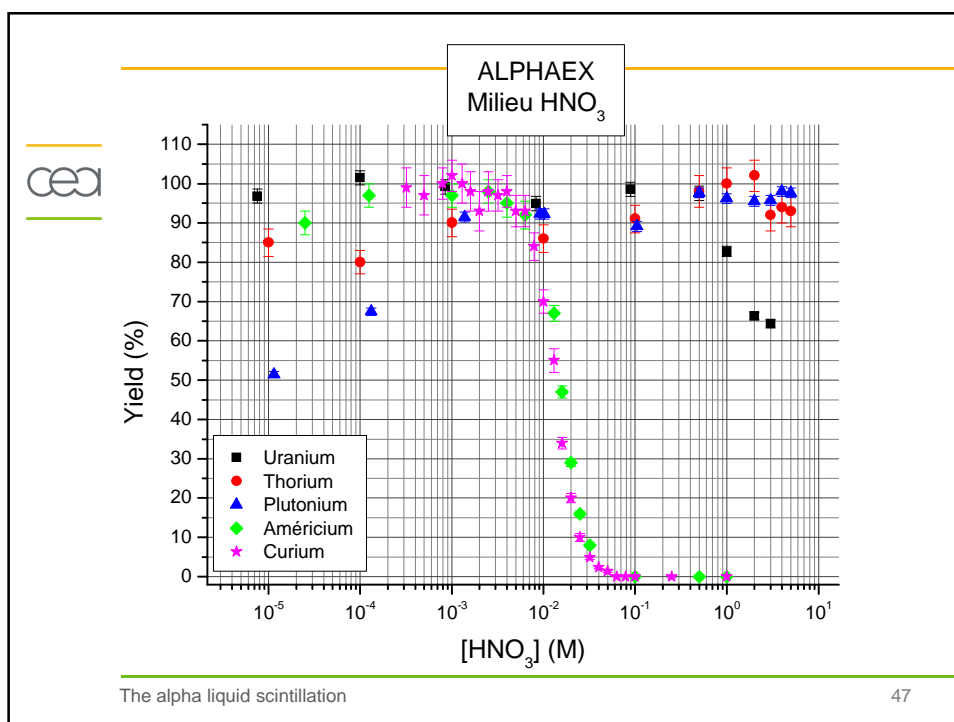

Sample preparation



1. Adjustment of the medium
2. Shaking of both phases (Turbula[®])
3. Centrifugation for separating both phases
4. Sampling of one aliquote of scintillating phase precisely
5. Deoxygenating by saturated-Ar bubling in toluene
6. Sealing of the tube
7. Counting in the spectrometer

System of deoxygenating

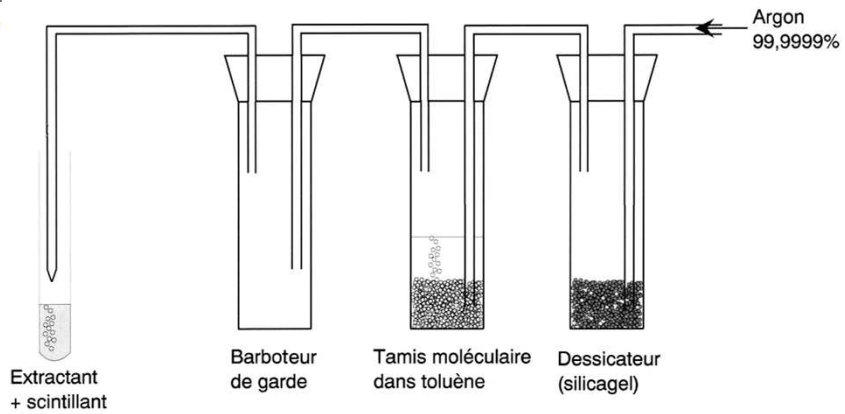

The alpha liquid scintillation

49

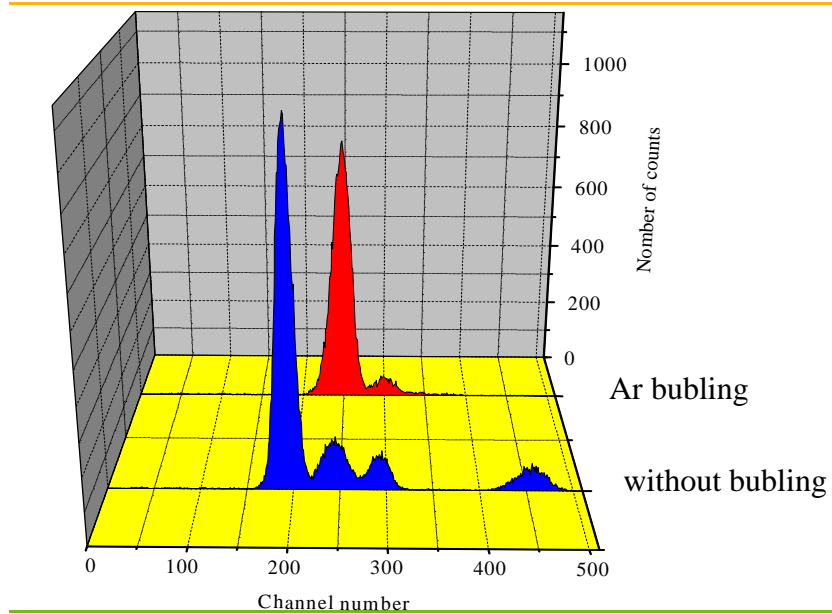

The alpha liquid scintillation

50

Solubility of radon into toluene

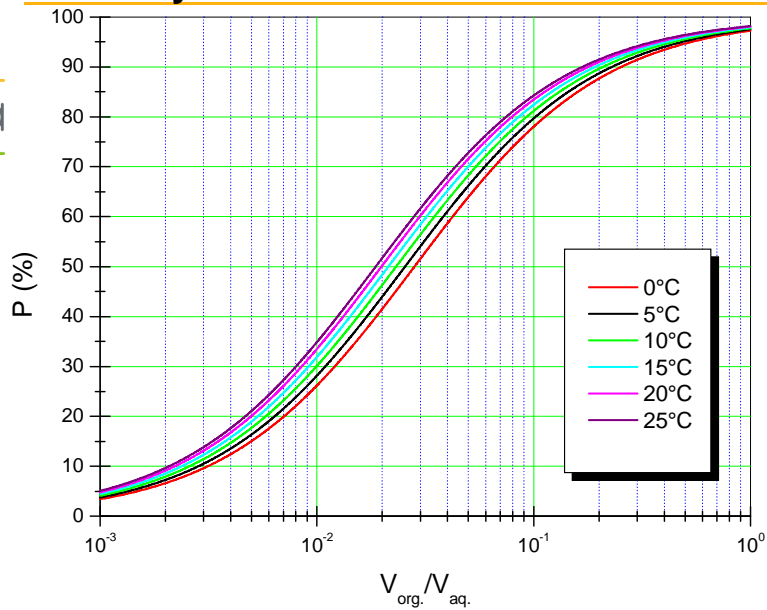

The alpha liquid scintillation

51



Extractive - scintillator cocktail :
ALPHAEX™

Extractant :
HDEHP (0.2 M)

Scintillating cocktail :

Solvent : toluene (10 M) 

α/β discrimination amplifier :

naphthalene (1.5 M) 

Scintillating molecule :

PBBO (10^{-2} M)

2-(4-biphenyl) 6-phenylbenzoxazole

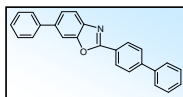

Water miscible scintillator cocktail :
ULTIMA Gold™

Detergents :
(27-42%)

Scintillating cocktail:

Solvent : di-isopropylnaphthalene (3 - 4.5 M) - 5 principal isomers (1,3-,1,4-, 1,7-, 2,6- and 2,7-)

Primary scintillator:

PPO $\approx 2.5 \cdot 10^{-2}$ M

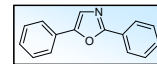

Secondary scintillator: bis-MSB

$\approx 1.5 \cdot 10^{-3}$ M

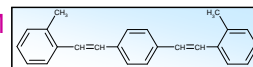

The alpha liquid scintillation

52

Experimental spectra



ALPHAEX

ULTIMA Gold

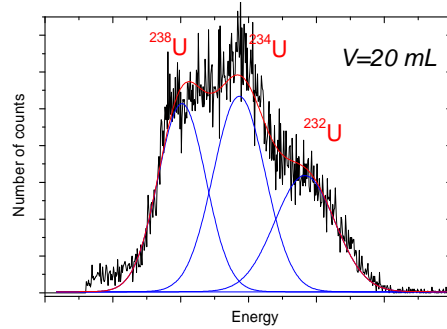
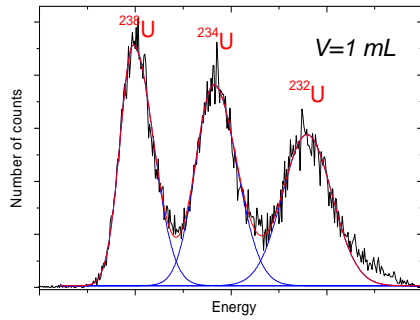

PERALS

TRICARB

The alpha liquid scintillation

53

TRICARB

No-water-miscible cocktail



Water-miscible cocktail

ULTIMA gold

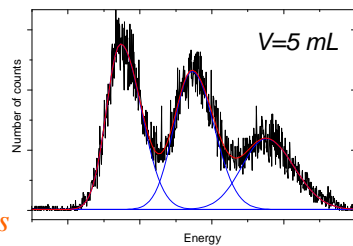
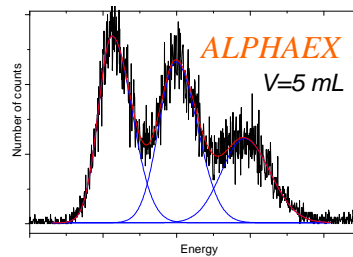
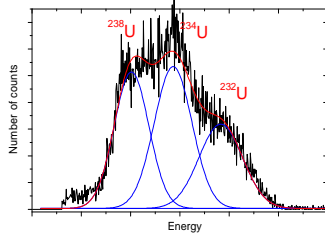

**ULTIMA gold
without detergents**

The alpha liquid scintillation

54

Effect of optical path (TRICARB)



**ULTIMA
gold**

L = 26 mm

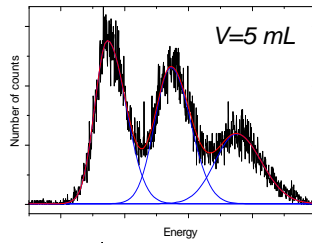

L = 16 mm

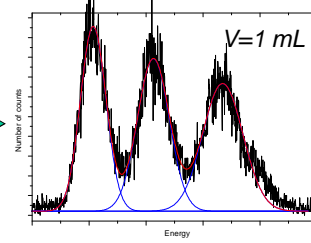

ALPHAEX

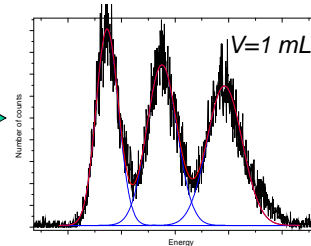
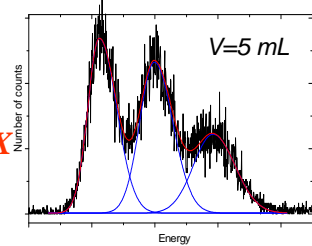

The alpha liquid scintillation

55

Comparison

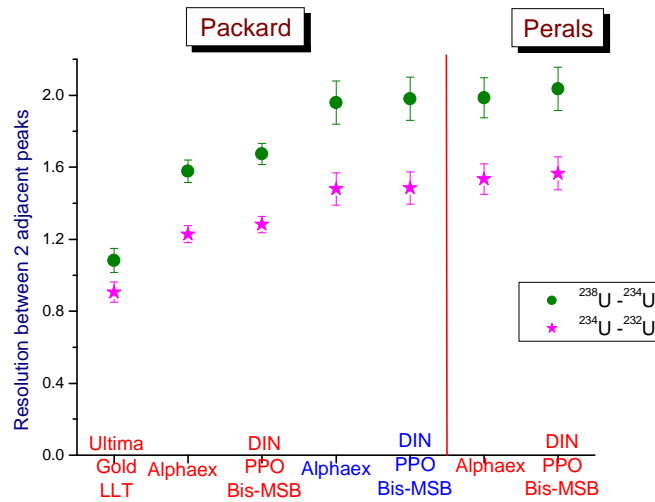

The alpha liquid scintillation

56

Detection limits



Isotope	↗ 40%			
	ALPHAEX (PERALS)	ALPHAEX (TRICARB)	DIN (TRICARB)	ULTIMA Gold (TRICARB)
²³² Th	1.5 10 ⁻⁸	2.8 10 ⁻⁸	2.7 10 ⁻⁸	1.1 10 ⁻⁷
²³⁴ U	2.6 10 ⁻¹³	4.9 10 ⁻¹³	4.7 10 ⁻¹³	1.9 10 ⁻¹²
²³⁸ U	4.8 10 ⁻⁹	9.3 10 ⁻⁹	8.5 10 ⁻⁹	3.6 10 ⁻⁸
²³⁷ Np	2.4 10 ⁻¹²	4.3 10 ⁻¹²	4.1 10 ⁻¹²	1.7 10 ⁻¹¹
²³⁸ Pu	9.6 10 ⁻¹⁷	1.8 10 ⁻¹⁶	1.7 10 ⁻¹⁶	6.9 10 ⁻¹⁶
²³⁹ Pu	2.6 10 ⁻¹⁴	4.9 10 ⁻¹⁴	4.6 10 ⁻¹⁴	1.9 10 ⁻¹³
²⁴¹ Am	4.8 10 ⁻¹⁶	8.4 10 ⁻¹⁶	8.2 10 ⁻¹⁶	3.4 10 ⁻¹⁵
²⁴⁴ Cm	2.0 10 ⁻¹⁷	3.6 10 ⁻¹⁷	3.5 10 ⁻¹⁷	1.4 10 ⁻¹⁶

↗ 4%

↘ 300%

The alpha liquid scintillation

57

Performances



Radionuclide	Detection limit (M)		Detection limit (pg/l)	
	3 days	10 days	3 days	10 days
²³² Th	1.10 ⁻⁹	3.10 ⁻¹⁰	3.10 ⁵	6.10 ⁴
²³⁸ U	2.10 ⁻¹⁰	9.10 ⁻¹¹	6.10 ⁴	2.10 ⁴
²³⁸ Pu	5.10 ⁻¹⁸	2.10 ⁻¹⁸	1.10 ⁻³	4.10 ⁻⁴
²³⁹ Pu	1.10 ⁻¹⁵	5.10 ⁻¹⁶	3.10 ⁻¹	1.10 ⁻¹
²⁴⁰ Pu	3.10 ⁻¹⁶	1.10 ⁻¹⁶	8.10 ⁻²	3.10 ⁻²
²⁴¹ Am	2.10 ⁻¹⁷	9.10 ⁻¹⁸	5.10 ⁻³	2.10 ⁻³
²⁴³ Am	4.10 ⁻¹⁶	1.10 ⁻¹⁶	9.10 ⁻²	4.10 ⁻²
²⁴⁴ Cm	9.10 ⁻¹⁹	4.10 ⁻¹⁹	2.10 ⁻⁴	9.10 ⁻⁵

Aliquot 250 mL

The alpha liquid scintillation

58

Applications : measure of An in environment

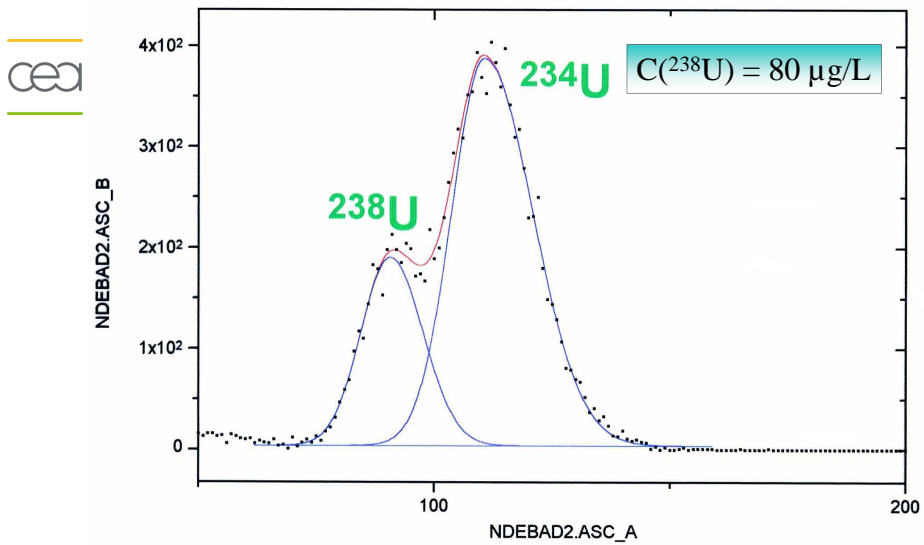

The alpha liquid scintillation

59

Badoit : ²¹⁰Po - A = 19.7 ± 1.6 mBq/L

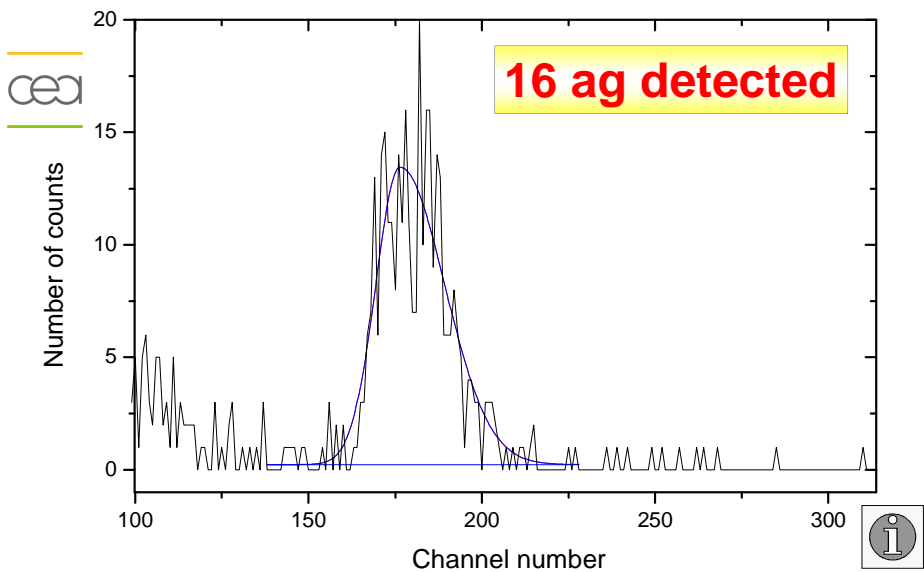

The alpha liquid scintillation

60

Spectrum Ra - La Bourboule

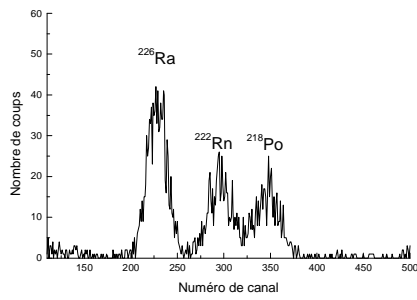

Sample	Extraction yield (%)	²²⁶ Ra (mBq.L ⁻¹)	²³⁸ U (μg.L ⁻¹)	
			ICP/MS	SLRT
Volvic	74 ± 4	28 ± 13	0,956 ± 0,016	0,82 ± 0,09
Cristaline	76 ± 4	< 39	2,03 ± 0,09	1,92 ± 0,05
Montjoie	81 ± 4	< 28	0,275 ± 0,012	0,8 ± 0,2
Aulus *	73 ± 3	254 ± 81	0,834 ± 0,035	
Chanteraine	83 ± 4	93 ± 18	(9,73 ± 3,82).10 ⁻³	
Fontestorbes	78 ± 4	< 24	0,377 ± 0,017	0,9 ± 0,1
Alet	79 ± 4	50 ± 12	2,30 ± 0,10	3,7 ± 0,5
Ax les thermes	70 ± 4	< 6	(1,48 ± 0,27).10 ⁻²	
Evian	67 ± 3	< 24	1,82 ± 0,08	
Badoit *	77 ± 4	2100 ± 250	76,6 ± 3,3	79 ± 2
Vittel	75 ± 4	< 24	0,984 ± 0,017	
Plancoët *	78 ± 4	75 ± 20	0,353 ± 0,015	0,41 ± 0,05
Contrex	65 ± 3	< 39	1,54 ± 0,07	1,4 ± 0,9
La Bourboule-Choussy	78 ± 4	3000 ± 200		

* Aliquote 1 mL, sinon 6 mL.

The alpha liquid scintillation

61

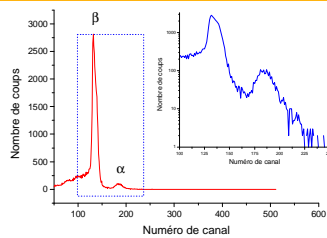

Initial ratio 10⁵ before extraction - A = 0.1 Bq, t = 7200 s

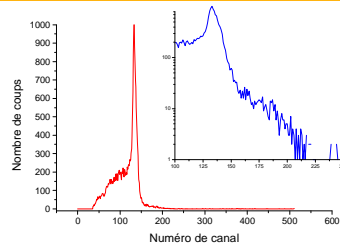

Initial ratio 10⁶ before extraction - A = 0.1 Bq, t = 7200 s

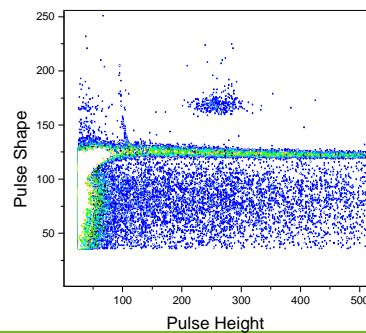

2D spectrum - PSD = 0,
Counting time 7200 s, A = 6 Bq/L



The alpha liquid scintillation

62

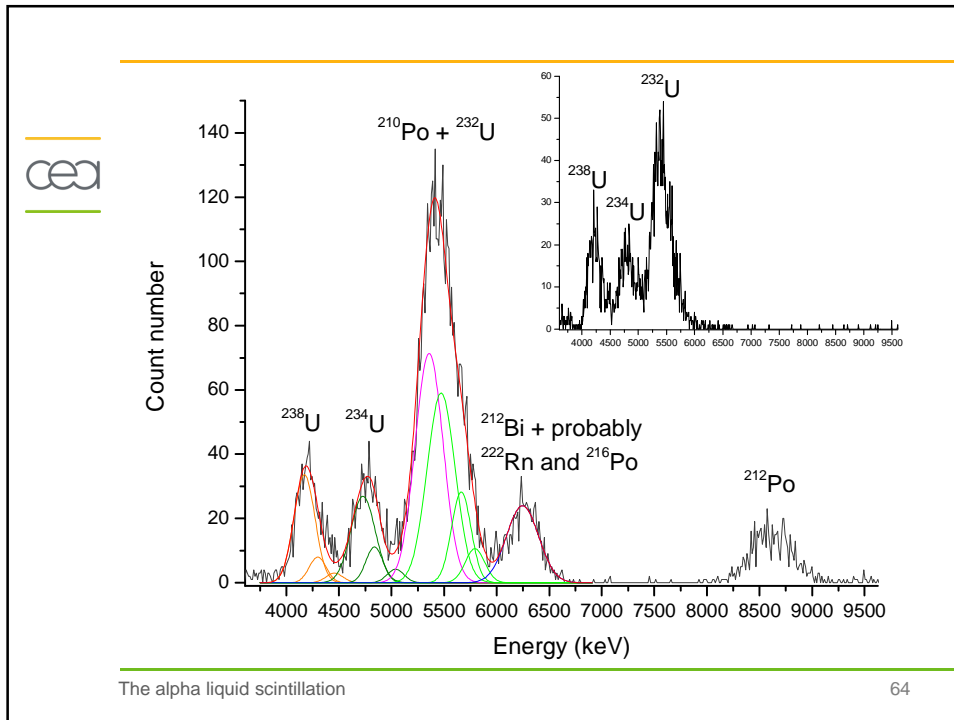
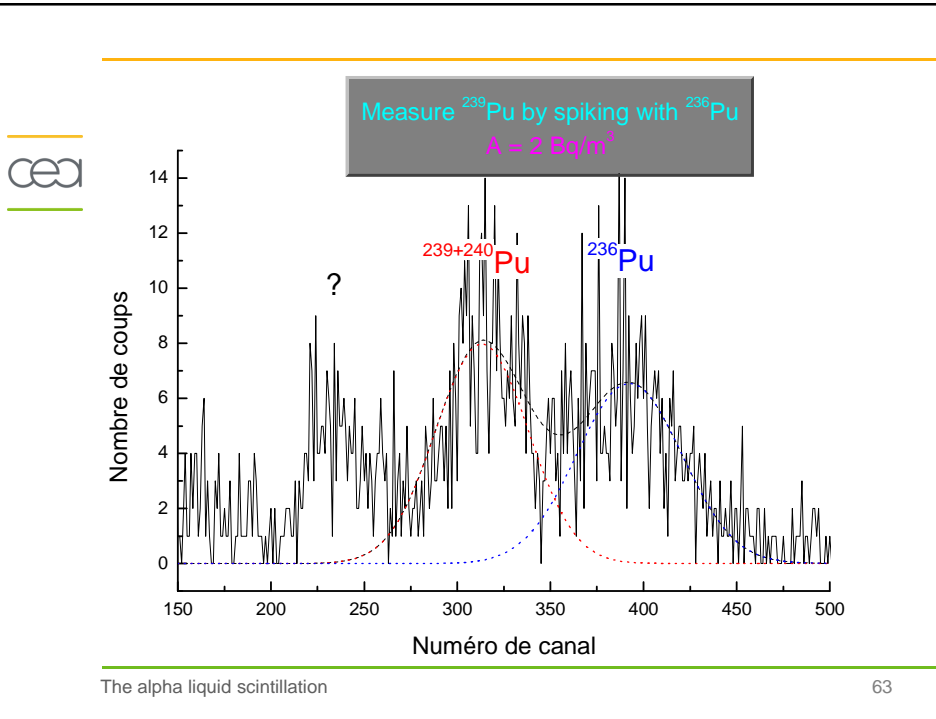

Determination of U in natural waters



$$u = \frac{|\text{Result} - \text{target}|}{\sqrt{(\text{uncertainty of result})^2 + (\text{uncertainty of target})^2}}$$

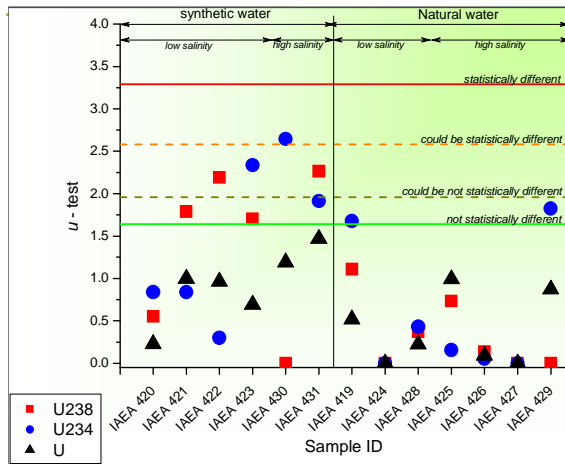

u values

$u < 1.64$

$1.64 < u < 1.96$

$1.96 < u < 2.58$

$2.58 < u < 3.29$

$3.29 < u$

Conclusion

Results not significantly different

Results could be not significantly different. Other determinations required

No conclusion can be drawn

Results could be significantly different. Other determinations required

Results significantly different

The alpha liquid scintillation

65

Intercomparison U & Ra well water (Finland)

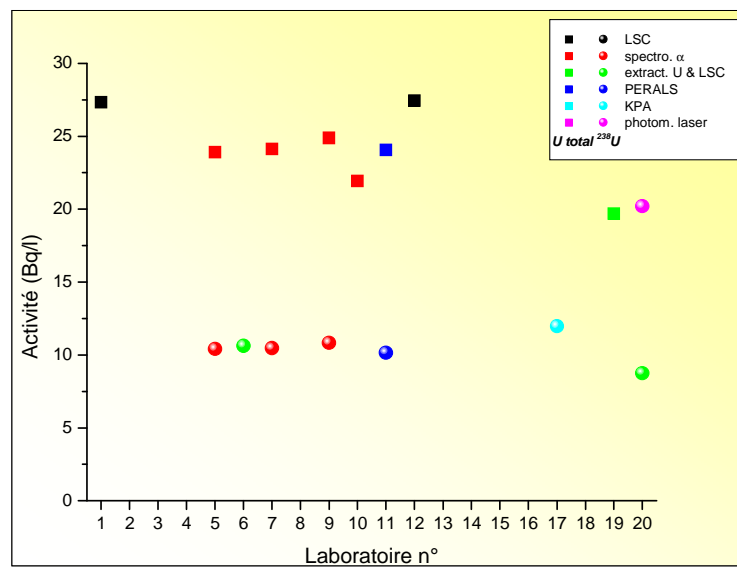

The alpha liquid scintillation

66

Radium 226

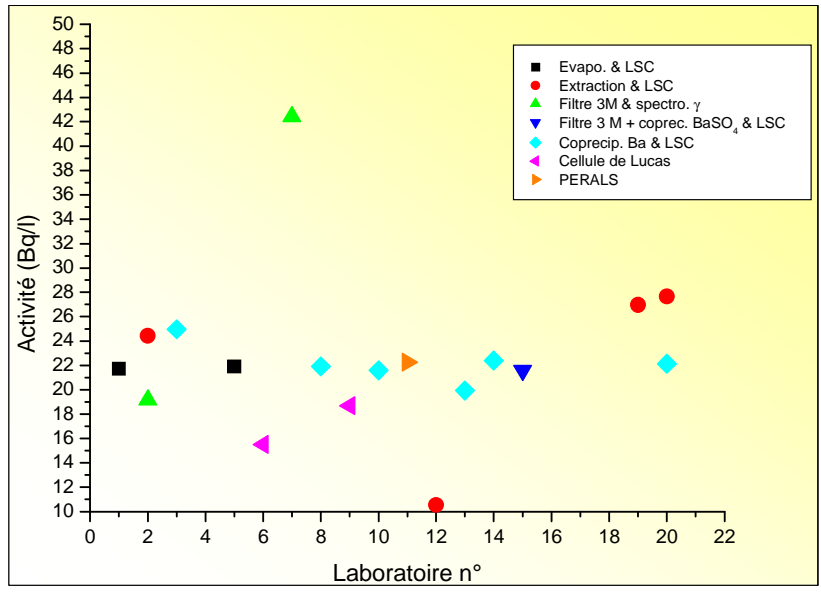

The alpha liquid scintillation

67

Energy diagram : fluorescence

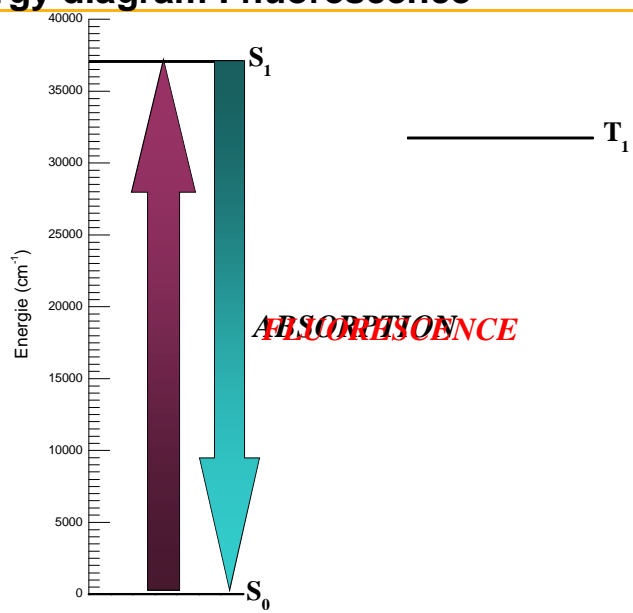

The alpha liquid scintillation

68

Energy diagram : internal conversion

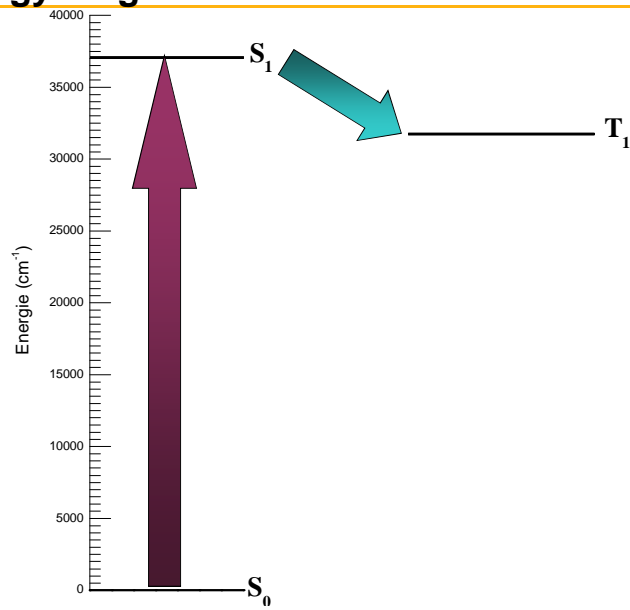

The alpha liquid scintillation

69

Mechanism of internal degradation

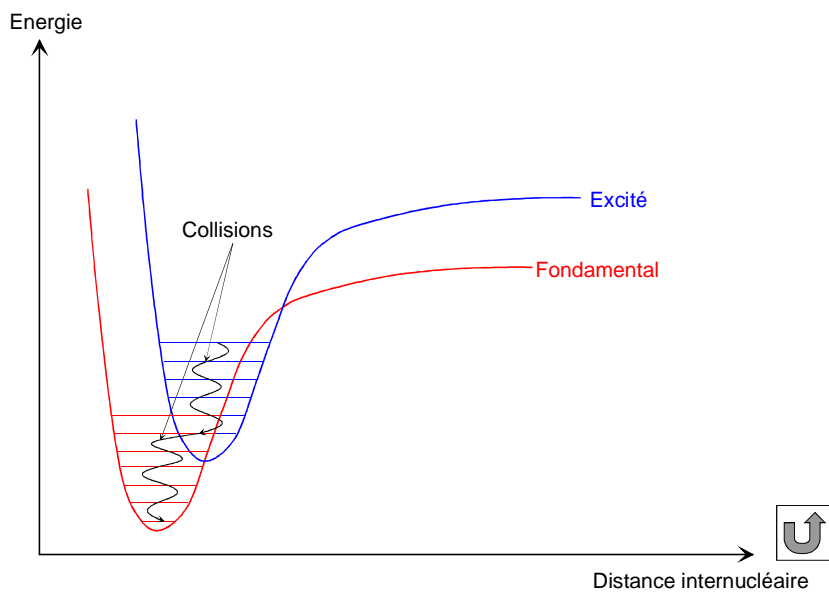

The alpha liquid scintillation

70

Energy diagram : phosphorescence

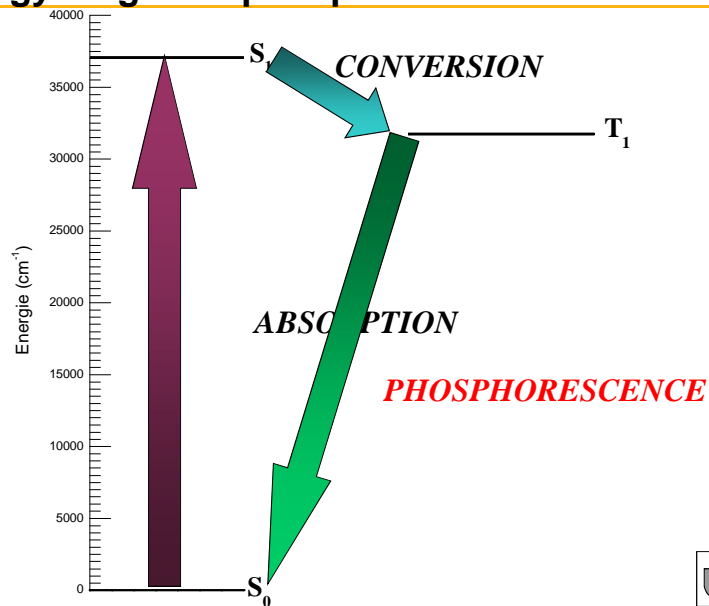

The alpha liquid scintillation

71

Kinetics of transfer and yield...

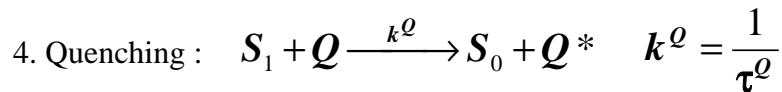
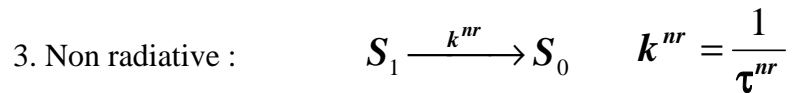
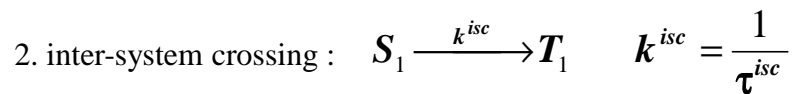
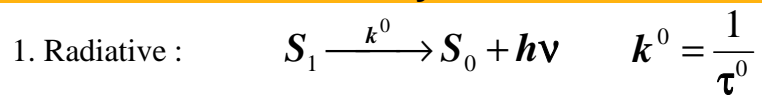

$$-\frac{d}{dt}[S_1] = k^0[S_1] + k^{isc}[S_1] + k^{nr}[S_1] + k^Q[Q][S_1]$$

$$[S_1] = [S_1]_0 \exp(-k^F t) \quad k^F = \frac{1}{\tau^F} = \sum_i k^i + k^Q[Q]$$

The alpha liquid scintillation

72

Kinetics of transfer and yield...

Quantum yield of fluorescence



$$\phi^F = \frac{k^F}{\sum_i k^i}$$

Quantum yield of phosphorescence

$$\phi^P = \frac{k^P}{k^P + k_{nr}} \phi^{isc}$$

With :

$$\phi^{isc} = \frac{k^{isc}}{\sum_i k^i}$$

Kinetics of transfer and yield...



$$\phi^F = \frac{k^F}{\sum_i k^i}$$

$$k^F = \phi^F \sum_i k^i$$

$$\frac{1}{\tau^F} = \phi^F \frac{1}{\tau}$$

$$\tau = \phi^F \tau^F$$

Reminder

$$\sum_i k^i = \frac{1}{\tau}$$



Rough estimation of time of transfer

For a reaction of pseudo first order



$$\frac{1}{t_{transfer}} = k_{diffusion} [acceptor]$$

Example of transfer toluene → naphthalene

$$[C_6H_5-CH_3] = 9.5 \text{ M} \quad [C_{10}H_8] = 1.5 \text{ M} \quad k_{diffusion} = 10^{10} \text{ M}^{-1}\text{s}^{-1}$$

$$T_{transfer} = 67 \cdot 10^{-12} \text{ s} = 67 \text{ ps}$$

Example of transfer naphthalene → PBBO

$$[C_{10}H_8] = 1.5 \text{ M} \quad [PBBO] = 10^{-2} \text{ M}$$

$$T_{transfert} = 10^{-8} \text{ s} = 10 \text{ ns}$$



The internal conversion : intensity



Isotope	α_T	$\alpha(L)$	$\alpha(M)$	$\alpha(N+...)$	$\alpha(L)/\alpha_T$	$\alpha(M)/\alpha_T$	$\alpha(M)/\alpha(L)$
²³⁰ Th	61.9	45.2	12.24	4.39	0.730	0.198	0.271
²³² Th	120	87.5	23.64	8.49	0.729	0.197	0.270
²³² U	156.1	113.6	31.1	11.44	0.728	0.199	0.274
²³⁴ U	232.9	169.6	46.3	17.07	0.728	0.199	0.273
²³⁶ Pu	461*	341*	94.1*	31.0*	0.740	0.204	0.276
²³⁸ Pu	731						
	724*	530*	146*	48.1*	0.732	0.202	0.275
²³⁹ Pu	317		---	---			---
	318 ± 6*	231 ± 4*			0.726	---	
²⁴⁰ Pu	597		---	---			---
	610 ± 9*	448 ± 7*			0.734	---	
²⁴¹ Am	1.16	0.84	0.226	0.094	0.724	0.195	0.269
²⁴³ Am	0.280	0.210	0.0518	0.0183	0.750	0.185	0.247
²⁴⁴ Cm	918						
	928 ± 9*	673 ± 7*	186*	61.5*	0.725	0.200	0.276

Calculation of IC intensity of related peaks

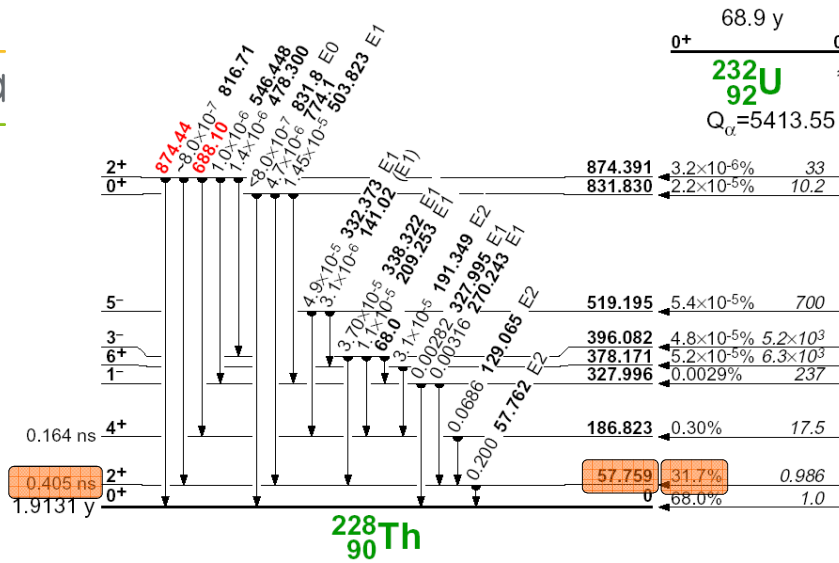

The alpha liquid scintillation

77

Nuclear data...



Isotope	E_α (keV)	I_α (%)	E_γ (keV)	τ (ns)	α_r	I_c	I_γ	E_{electron} (keV) (L shell)	E_{electron} (keV) (M shell)
^{228}Th	5340.36	27.2	84.37	0.746	21.6	0.9558	0.0442	65.55	80.19
^{230}Th	4620.5	23.4	67.67	0.63	61.9	0.9841	0.0159	48.85	63.49
^{232}Th	3947.2	21.7	63.81	0.55	81.9	0.9879	0.0121	45.00	54.82
^{232}U	5263.36	31.55	57.78	0.406	156	0.9936	0.0064	37.82	53.32
^{233}U	4783	13.23	42.44	0.172	4500	0.9998	0.0002	22.48	37.98
^{234}U	4722.4	28.42	53.20	0.354	232.9	0.9957	0.0043	33.24	48.74
^{238}U	4151	20.8	49.55	0.25	235.4	0.9959	0.0041	29.59	45.09
^{236}Pu	5721	31						26.46	42.84
^{238}Pu	5456.3	28.84	42.50	0.252	231	0.9985	0.0014	22.36	38.72
^{239}Pu	5144.3	15						--	--
	5105.5	11.5	51.62	0.191	317	0.9967	0.0031	30.48	46.86
^{240}Pu	5123.68	27						24.10	40.48
^{242}Pu	4856.3	22.4	47.51	0.223	617	0.9984	0.0016	23.77	40.17
^{241}Am	5485.56	84.5	59.54	67	1.16	0.537	0.463	37.78	54.63
	5442.80	13.0	102.98	0.08	0.121	0.108	0.892	81.22	98.07
^{243}Am	5275	87.9	74.67	1.40	0.280	0.219	0.781	52.91	69.76
	5233	10.6	117.66	< 0.04	--	--	--	--	112.75
^{244}Cm	5762.70	23.6	42.82	0.164	918	0.9989	0.0011	20.44	37.74

The alpha liquid scintillation

78

Nuclear data...



Isotope	E_α (keV)	I_α (%)	E_γ (keV)	τ (ns)	α_r	I_{ic}	I_γ	$E_{electron}$ (keV) (L shell)	$E_{electron}$ (keV) (M shell)
^{228}Th	5340.36	27.2	84.37	0.746	21.6	0.9558	0.0442	65.55	80.19
^{230}Th	4620.5	23.4	67.67	0.63	61.9	0.9841	0.0159	48.85	63.49
^{232}Th	3947.2	21.7	63.81	0.55	81.9	0.9879	0.0121	45.00	54.82
^{232}U	5263.36	31.55	57.78	0.406	156	0.9936	0.0064	37.82	53.32
^{233}U	4783	13.23	42.44	0.172	4500	0.9998	0.0002	22.48	37.98
^{234}U	4722.4	28.42	53.20	0.354	232.9	0.9957	0.0043	33.24	48.74
^{238}U	4151	20.9	49.55	0.37	326.4	0.9969	0.0031	29.59	45.09
^{236}Pu	5721	31.7	47.6	0.254	461	0.9978	0.0021	26.46	42.84
^{238}Pu	5456.3	28.84	43.50	0.252	731	0.9986	0.0014	22.36	38.72
^{239}Pu	5144.3	15.1	13.0	0.50	$\approx 3.10^4$	1	0	--	--
	5105.5	11.5	51.62	0.191	317	0.9967	0.0031	30.48	46.86
^{240}Pu	5123.68	27.1	45.24	0.234	597	0.9983	0.0017	24.10	40.48
^{242}Pu	4856.3	22.4	44.91	0.225	619	0.9984	0.0016	23.77	40.17
^{241}Am	5485.56	84.5	59.54	67	1.16	0.537	0.463	37.78	54.63
	5442.80	13.0	102.98	0.08	0.121	0.108	0.892	81.22	98.07
^{243}Am	5275	87.9	74.67	1.40	0.280	0.219	0.781	52.91	69.76
	5233	10.6	117.66	< 0.04	---	---	---	---	112.75
^{244}Cm	5762.70	23.6	42.82	0.164	918	0.9989	0.0011	20.44	37.74

The alpha liquid scintillation

79

Position of IC peaks

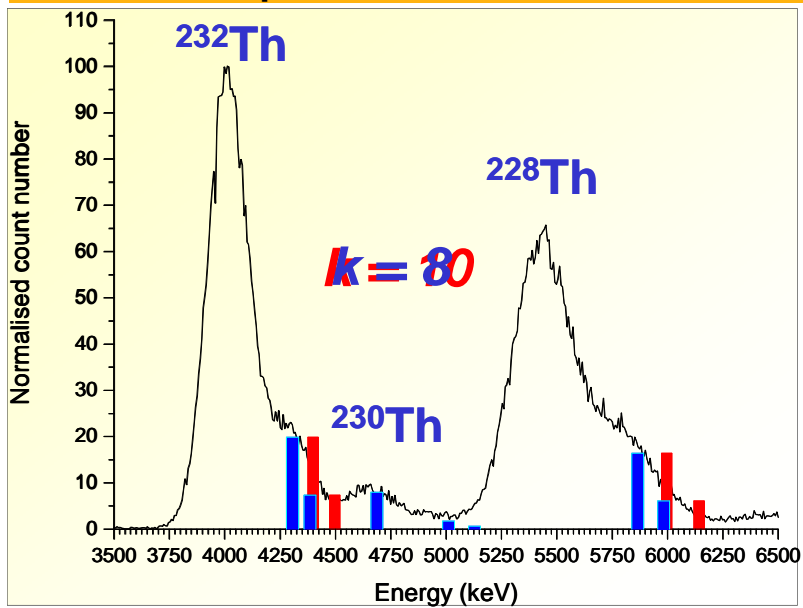

The alpha liquid scintillation

80

Calculation of the number of detected atoms



$${}^{210}\text{Po}: T_{1/2} = 138.376 \text{ d}$$

Sample volume = 200 mL

Volume of extracting-scintillating phase = 1.5 mL

Volume of measured extracting-scintillating phase = 1.0 mL

Number of ${}^{210}\text{Po}$ atoms inside the tube ?

$$A = \lambda N$$

$$N = 19.6 \cdot 10^{-3} \times 138.376 \times 86400 \times \frac{1}{\ln 2} \text{ at./L}$$

$$m = \frac{N}{6.02 \cdot 10^{23}} \times 210 \times \frac{1}{1.5} \times \frac{200}{1000} = 15.7 \text{ ag}$$



Extraction yield calculation



Definition : A_T overall activity

A_1 activity found after the first extraction

A_2 activity found after the second extraction

R the extraction yield

Link R with A_1 and A_2

$$A_1 = R \times A_T$$

$$A_2 = R \times (A_T - A_1)$$

$$R = \frac{A_1 - A_2}{A_1}$$

